Topic 14

Testing

Peter Y. K. Cheung
Department of Electrical & Electronic Engineering
Imperial College London

URL: <http://www.ee.ic.ac.uk/pcheung>

Based on slides/material by...

- ◆ K. Masselos <http://cas.ee.ic.ac.uk/~kostas>
- ◆ J. Rabaey <http://bwrc.eecs.berkeley.edu/Classes/IcBook/instructors.html>
“Digital Integrated Circuits: A Design Perspective”, Prentice Hall
- ◆ D. Harris <http://www.cmosvlsi.com/coursematerials.html>
Weste and Harris, “CMOS VLSI Design: A Circuits and Systems Perspective”, Addison Wesley

Recommended Reading:

- ◆ J. Rabaey et. al. “Digital Integrated Circuits: A Design Perspective”:
Design Methodology Insert H
- ◆ Weste and Harris, “CMOS VLSI Design: A Circuits and Systems Perspective”: Chapter 9

Testing

- ◆ Testing is one of the most expensive parts of chips
 - Logic verification accounts for > 50% of design effort for many chips
 - Debug time after fabrication has enormous opportunity cost
 - Shipping defective parts can sink a company
- ◆ Example: Intel FDIV bug
 - Logic error not caught until > 1M units shipped
 - Recall cost \$450M (!!!)

Logic Verification

- ◆ Does the chip simulate correctly?
 - Usually done at HDL level
 - Verification engineers write test bench for HDL
 - Can't test all cases
 - Look for corner cases
 - Try to break logic design
- ◆ Ex: 32-bit adder
 - Test all combinations of corner cases as inputs:
 - 0, 1, 2, $2^{31}-1$, -1, -2^{31} , a few random numbers
- ◆ Good tests require ingenuity

Silicon Debug

- ◆ Test the first chips back from fabrication
 - If you are lucky, they work the first time
 - If not...
- ◆ Logic bugs vs. electrical failures
 - Most chip failures are logic bugs from inadequate simulation
 - Some are electrical failures
 - Crosstalk
 - Dynamic nodes: leakage, charge sharing
 - Ratio failures
 - A few are tool or methodology failures (e.g. DRC)
- ◆ Fix the bugs and fabricate a corrected chip

Shmoo Plots

- ◆ How to diagnose failures?
 - Hard to access chips
 - Picoprobes
 - Electron beam
 - Laser voltage probing
 - Built-in self-test
- ◆ Shmoo plots
 - Vary voltage, frequency
 - Look for cause of electrical failures

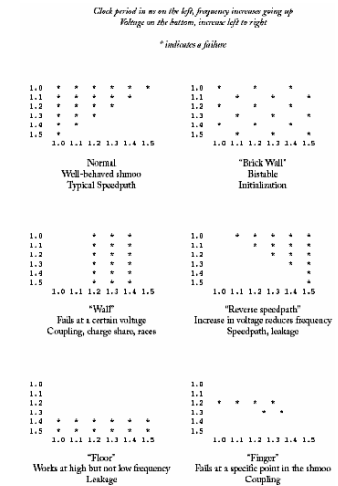

Manufacturing Test

- ◆ A speck of dust on a wafer is sufficient to kill chip
- ◆ Yield of any chip is < 100%
 - Must test chips after manufacturing before delivery to customers to only ship good parts
- ◆ Manufacturing testers are very expensive
 - Minimize time on tester
 - Careful selection of *test vectors*



Validation and Test of Manufactured Circuits

Goals of Design-for-Test (DFT)

Make testing of manufactured part swift and comprehensive

DFT Mantra

Provide controllability and observability

Components of DFT strategy

- Provide circuitry to enable test
- Provide test patterns that guarantee reasonable coverage

Test Classification

- ◆ Diagnostic test
 - used in chip/board debugging
 - defect localization
- ◆ “go/no go” or production test
 - Used in chip production
- ◆ Parametric test
 - $x \in [v, i]$ versus $x \in [0, 1]$
 - check parameters such as NM, Vt, tp, T

Design for Testability

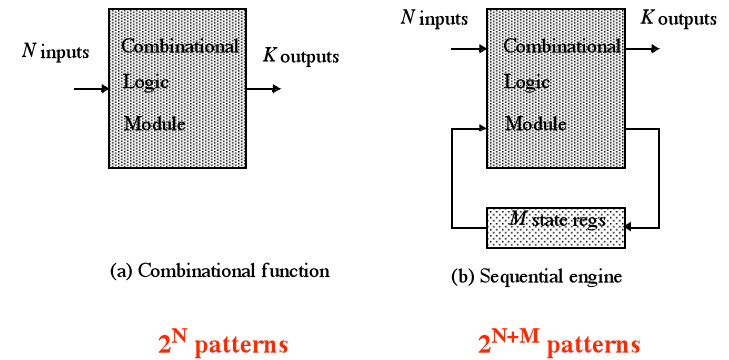

Exhaustive test is impossible or unpractical

Design for Test

- ◆ Design the chip to increase observability and controllability
- ◆ If each register could be observed and controlled, test problem reduces to testing combinational logic between registers.
- ◆ Better yet, logic blocks could enter test mode where they generate test patterns and report the results automatically.

Controllability/Observability

- ◆ Combinational Circuits:
 - controllable and observable - relatively easy to determine test patterns
- ◆ Sequential Circuits: State!
 - Turn into combinational circuits or use self-test
- ◆ Memory: requires complex patterns
 - Use self-test

Generating and Validating Test-Vectors

- ◆ Automatic test-pattern generation (ATPG)
 - for given fault, determine excitation vector (called **test vector**) that will propagate error to primary (observable) output
 - majority of available tools: combinational networks only
 - sequential ATPG available from academic research
- ◆ Fault simulation
 - determines **test coverage** of proposed test-vector set
 - simulates correct network in parallel with faulty networks
- ◆ Both require adequate models of faults in CMOS integrated circuits

Fault Models

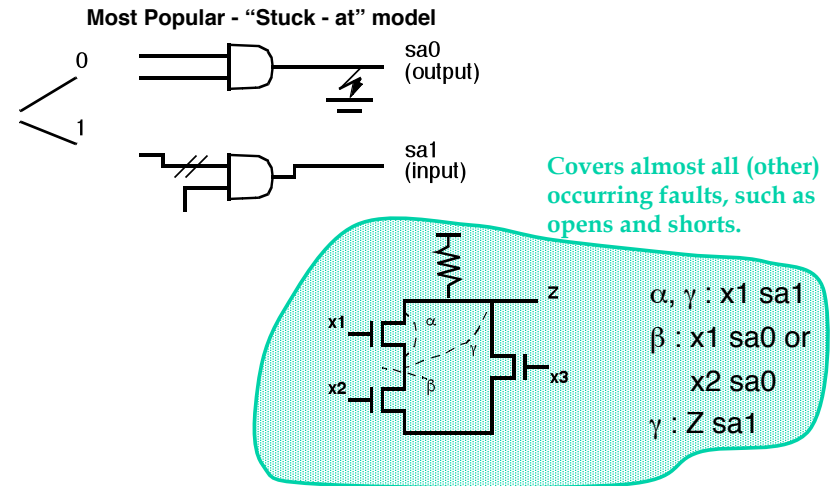

Problem with stuck-at model: CMOS open fault

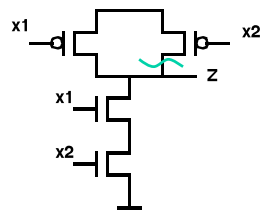

x1	x2	Z
0	x	1
1	1	0
1	0	Z _{n-1}

Sequential effect

Needs two vectors to ensure detection!

Other options: use stuck-open or stuck-short models

This requires fault-simulation and analysis at the switch or transistor level - Very expensive!

Problem with stuck-at model: CMOS short fault

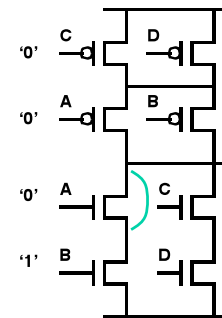

Causes short circuit between Vdd and GND for A=C=0, B=1

Possible approach: Supply Current Measurement (IDDQ) but: not applicable for gigascale integration

Test Pattern Generation

- ◆ Manufacturing test ideally would check every node in the circuit to prove it is not stuck.
- ◆ Apply the smallest sequence of test vectors necessary to prove each node is not stuck.
- ◆ Good observability and controllability reduces number of test vectors required for manufacturing test.
 - Reduces the cost of testing
 - Motivates design-for-test

Path Sensitization

Goals: Determine input pattern that makes a fault controllable (triggers the fault, and makes its impact visible at the output nodes)

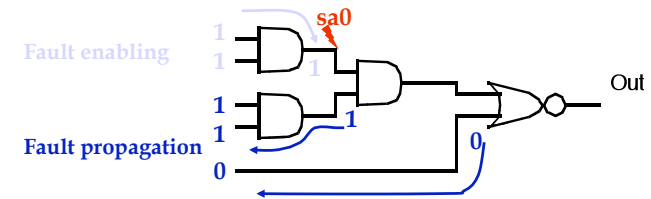

Techniques Used: D-algorithm, Podem

Test Example

	SA1	SA0
◆ A_3	{0110}	{1110}
◆ A_2	{1010}	{1110}
◆ A_1	{0100}	{0110}
◆ A_0	{0110}	{0111}
◆ n1	{1110}	{0110}
◆ n2	{0110}	{0100}
◆ n3	{0101}	{0110}
◆ Y	{0110}	{1110}

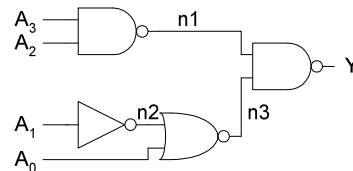

- ◆ Minimum set: {0100, 0101, 0110, 0111, 1010, 1110}

Test Approaches

- ◆ Ad-hoc testing
- ◆ Scan-based Test
- ◆ Self-Test

Problem is getting harder

- increasing complexity and heterogeneous combination of modules in system -on-a-chip.
- Advanced packaging and assembly techniques extend problem to the board level

Ad-hoc Test

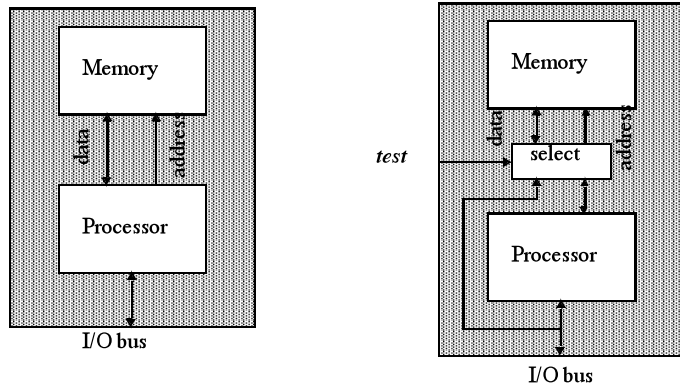

Inserting multiplexer improves testability

Scan

- ◆ Convert each flip-flop to a scan register
 - Only costs one extra multiplexer
- ◆ Normal mode: flip-flops behave as usual
- ◆ Scan mode: flip-flops behave as shift register

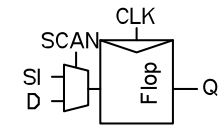

- ◆ Contents of flops can be scanned out and new values scanned in

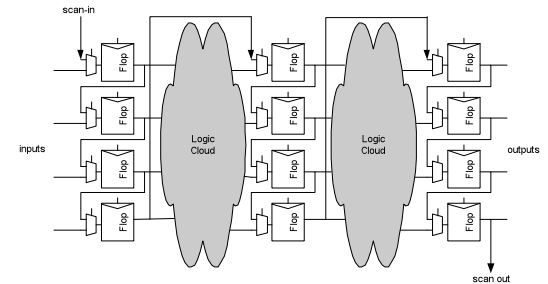

Scan-based Test

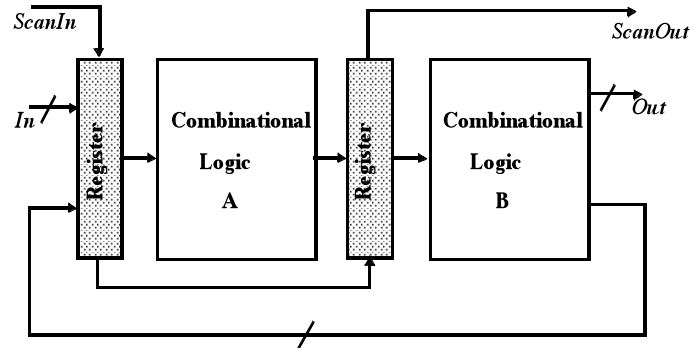

Scannable Flip-flops

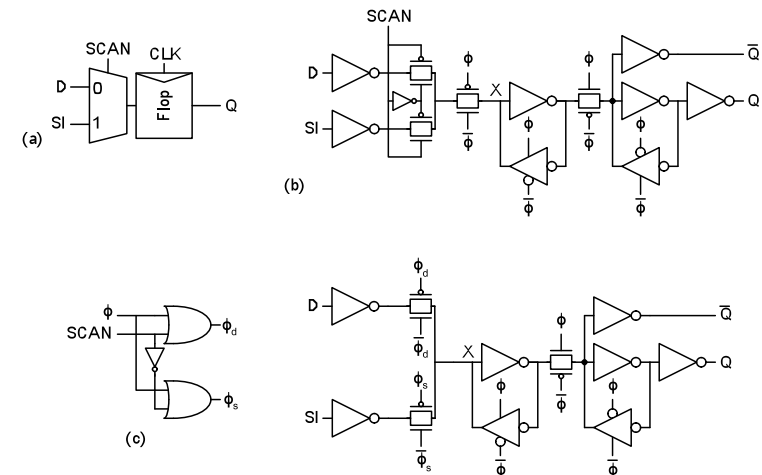

Polarity-Hold SRL (Shift-Register Latch)

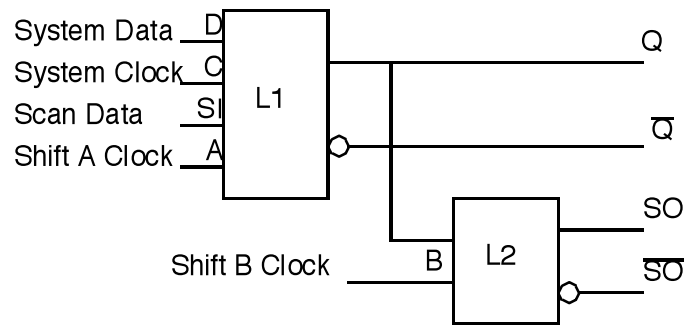

Introduced at IBM and set as company policy

Scan-based Test — Operation

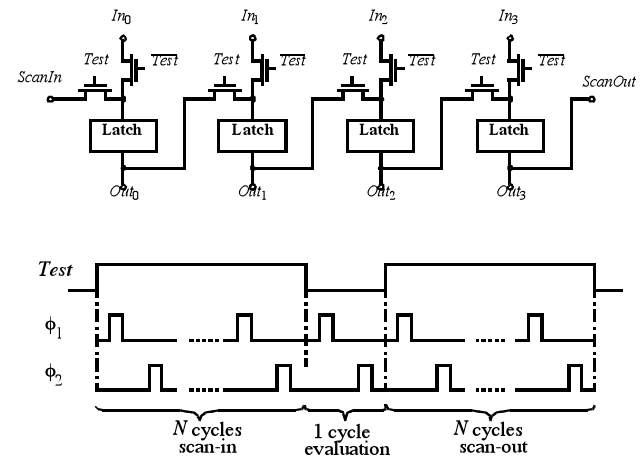

Scan-Path Testing

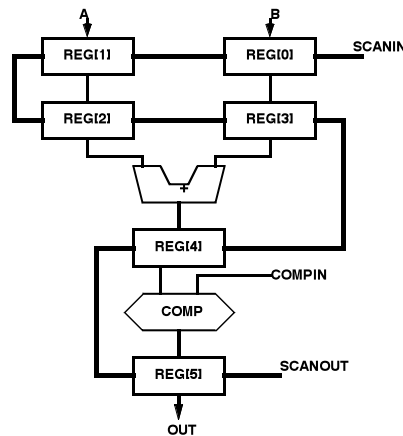

Partial-Scan can be more effective for pipelined datapaths

Boundary Scan

- ◆ Testing boards is also difficult
 - Need to verify solder joints are good
 - > Drive a pin to 0, then to 1
 - > Check that all connected pins get the values
- ◆ Through-hole boards used “bed of nails”
- ◆ SMT and BGA boards cannot easily contact pins
- ◆ Build capability of observing and controlling pins into each chip to make board test easier

Boundary Scan (JTAG)

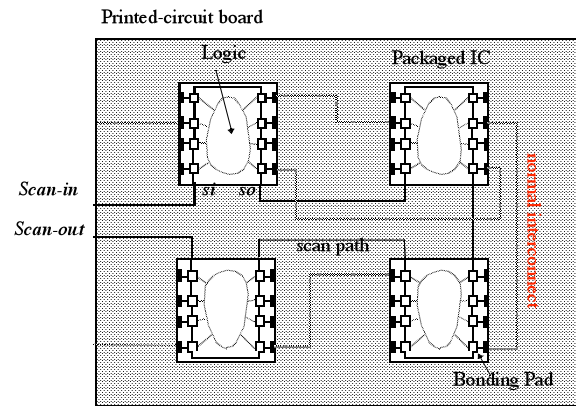

Board testing becomes as problematic as chip testing

Boundary Scan Example

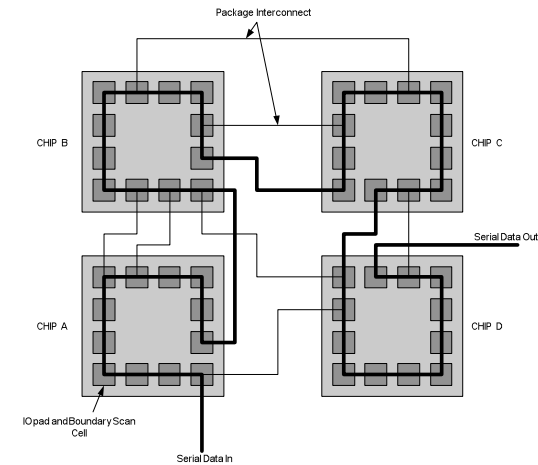

Boundary Scan Interface

- ◆ Boundary scan is accessed through five pins
 - TCK: test clock
 - TMS: test mode select
 - TDI: test data in
 - TDO: test data out
 - TRST*: test reset (optional)
- ◆ Chips with internal scan chains can access the chains through boundary scan for unified test strategy.

Built-in Self-test

- ◆ Built-in self-test lets blocks test themselves
 - Generate pseudo-random inputs to comb. logic
 - Combine outputs into a *syndrome*
 - With high probability, block is fault-free if it produces the expected syndrome

Self-test

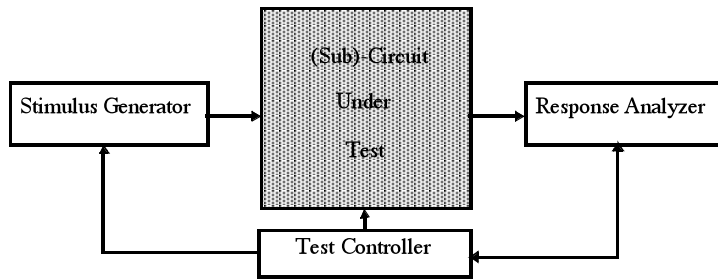

Rapidly becoming more important with increasing chip-complexity and larger modules

PRSG

- ◆ *Linear Feedback Shift Register*
 - Shift register with input taken from XOR of state
 - *Pseudo-Random Sequence Generator*

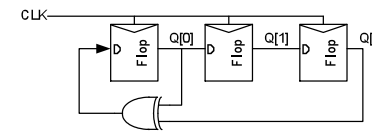

Step	Q
0	111
1	110
2	101
3	010
4	100
5	001
6	011
7	111 (repeats)

Linear-Feedback Shift Register (LFSR)

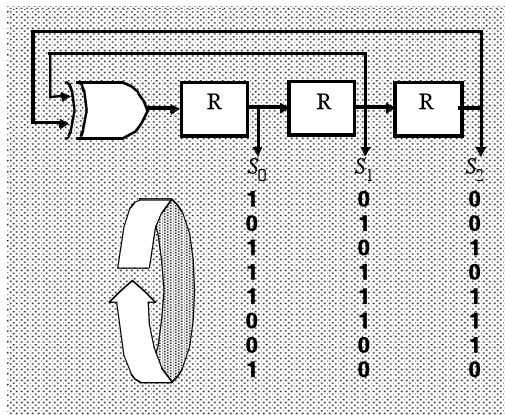

Pseudo-Random Pattern Generator

Signature Analysis

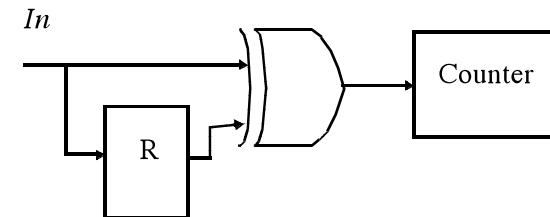

Counts transitions on single-bit stream
= Compression in time

BILBO

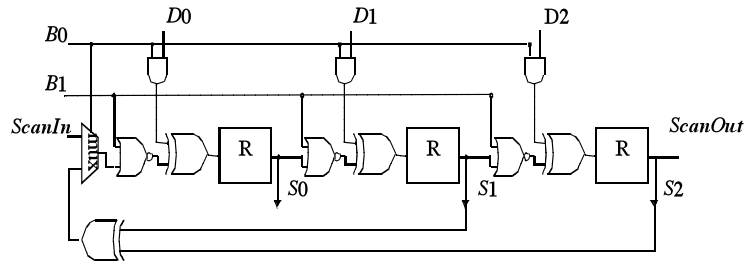

B_0	B_1	Operation mode
1	1	Normal
0	0	Scan
1	0	Pattern generation or Signature analysis
0	1	Reset

BILBO Application

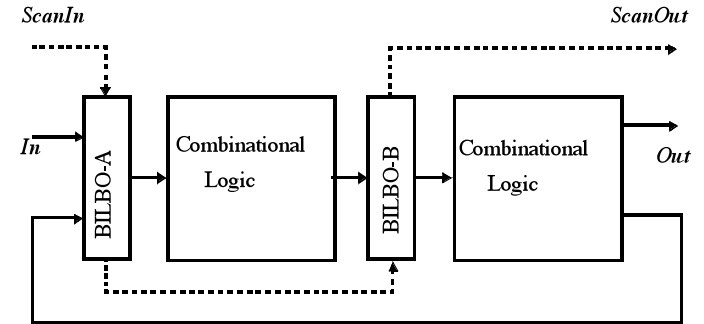

BILBO

- ◆ Built-in Logic Block Observer
 - Combine scan with PRSG & signature analysis

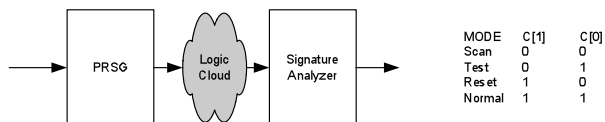
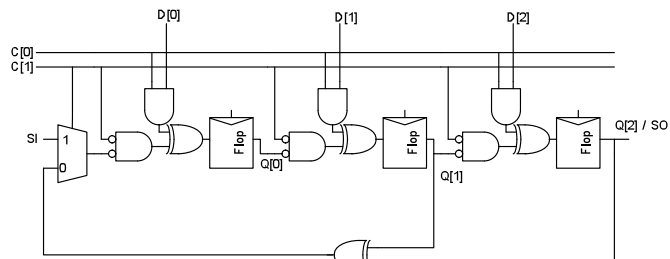

Memory Self-Test

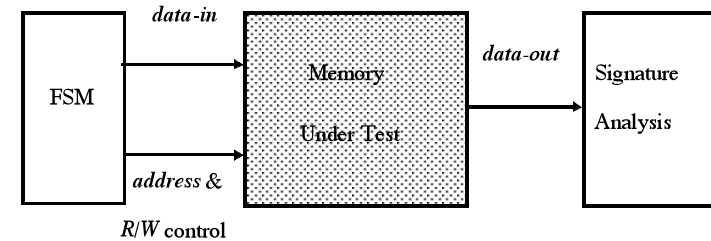

Patterns: Writing/Reading 0s, 1s,
Walking 0s, 1s
Galloping 0s, 1s

Low Cost Testing

- ◆ If you don't have a multimillion dollar tester:
 - Build a breadboard with LED's and switches
 - Hook up a logic analyzer and pattern generator
 - Or use a low-cost functional chip tester

TestosterICs

- ◆ Ex: TestosterICs functional chip tester
 - Designed by clinic teams and David Diaz at HMC
 - Reads your IRSIM test vectors, applies them to your chip, and reports assertion failures

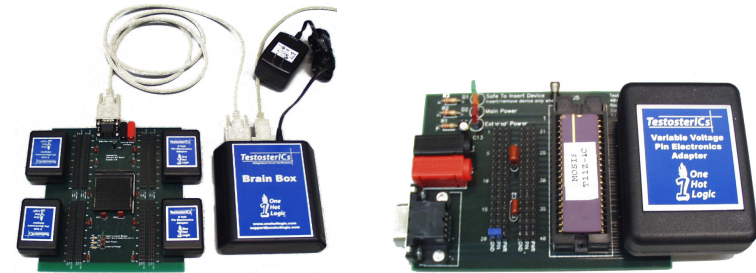

Summary

- ◆ Think about testing from the beginning
 - Simulate as you go
 - Plan for test after fabrication
- ◆ “If you don't test it, it won't work! (Guaranteed)”